



Segment Collar Couplings Storz - NFPA 1963

Segment collar couplings connect and secure hose lines using collar binding bands, ensuring a strong and pressure-resistant hose connection.

General Data

Manufacturer	JMW Fire d.o.o.
Model	Segment collar coupling Storz
Types	B-75; St. 100-100 ; A-100; A-110; St. 125-125; St.150-150; St. 205-205
Standard	NFPA 1963
Material	Aluminium alloy, optional: stainless lock/ tapped version/anodized version

1	Coupling
2	Tail piece
3	Segment
4	Bolt
5	Nut (only at bolt-nut-version)

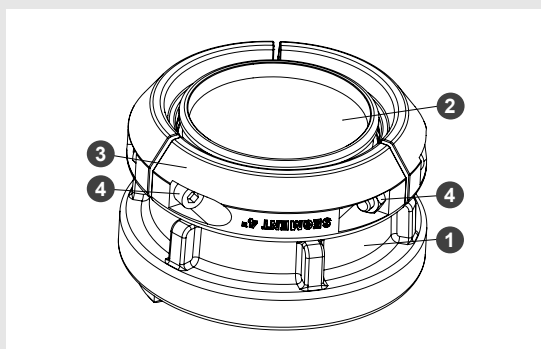

Technical Data

Types (Size)	B-75	St. 100-100	A-100	A-110	St. 125-125	St. 150-150	St. 205-205
Lug spacing (mm)	89	115	133	133	148	160,5	221
Ø Hose inside (mm)*	75	101	101	110	125	150	205
L tail piece (mm)	82	84	90	90	90	100	140
Weight (kg)	1,1	1,7	2,2	2,3	2,6	3,45	7,5
Lock	Locking available as option						
Tapped segments	On request	Tapped segments available as option				On request	
Anodization	Anodization available as option						
ID No.**	1010566	1010550	1012448	1012454	1010553	1010554	1010557

* Collars and tails can be adapted to other hose inside diameters.

** Bolt-nut-version, without lock, without anodization.

Subject to technical modifications and errors - Illustrations for reference only.

